



Matière:
Acier.

Finition:
Poli.

Exemple de commande:
nlm 08000-02

Nota:
Ressort, goupille cylindrique et rondelles de compensation fournis. Assortiments complets d'éléments de montage de perçage: voir nlm 08250 à nlm 08280.

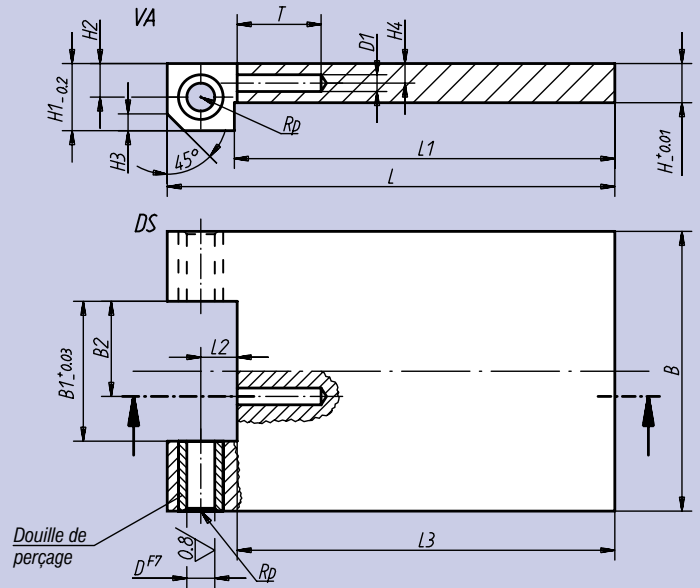
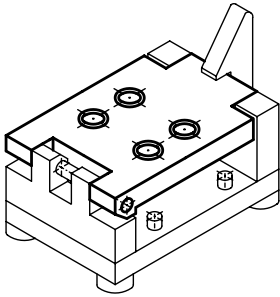

Référence	L	L ₁	L ₂	L ₃	B	B ₁ ^{+0,03}	B ₂	H ^{+0,01}	H _{1-0,2}	H ₂	H ₃	H ₄	D ^{F7}	D ₁	T	kg
08000-01	80	68	6,5	67,5	50	25	17	7	12	6	4,0	2,5	5	3	15	0,205
08000-02	100	84	8,5	83,5	65	32	22	9	15	8	5,5	3,0	6	3	15	0,430
08000-03	150	130	10,5	129,5	100	50	33	16	20	10	7,5	5,0	8	3	15	1,755



Matière:
Acier.

Finition:
Phosphaté.

Exemple de commande:
nlm 08050-01

Nota:
Assortiments complets d'éléments de montage de perçage: voir nlm 08250 à nlm 08280.

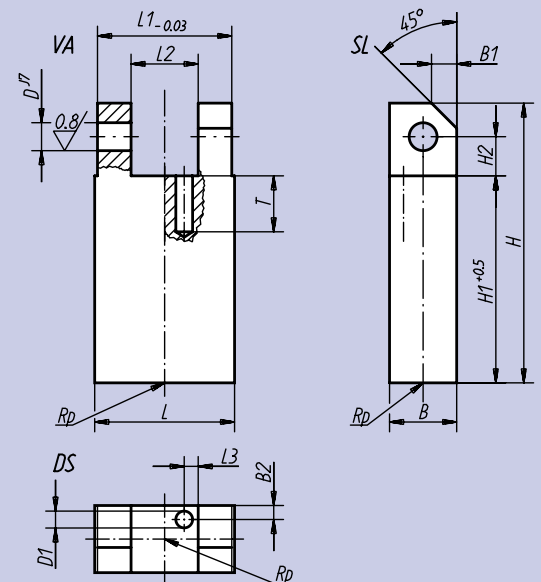
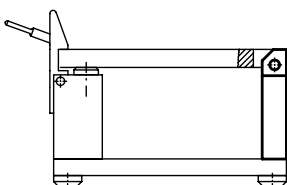

Référence	L	L _{1-0,03}	L ₂	L ₃	B	B ₁	B ₂	H	H _{1+0,5}	H ₂	T	D ^{J7}	D ₁	kg
08050-01	25	24	12	2,5	12	4,5	2,5	50	37	7	10	5	3	0,096
08050-02	32	31	16	2,5	16	6,0	2,5	63	46	9	10	6	3	0,195
08050-03	50	49	20	2,5	20	8,0	2,5	100	79	11	10	8	3	0,705