

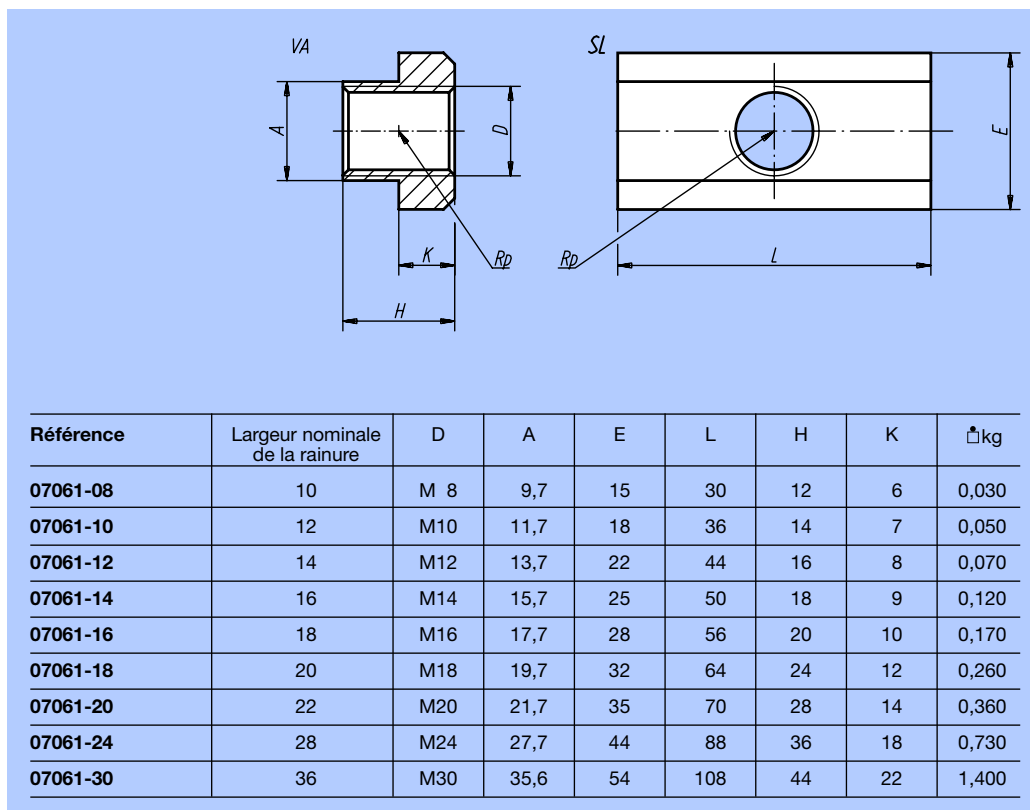

Matière:
Acier classe 10.

Finition:
Bruni.

Exemple de commande:
nlm 07061-12



Matière:
Acier de traitement,
Al Zn Mg Cu 1,5 F 49 (3.4365)
ou Inox 1.4305.

Exemple de commande:
nlm 07070-16

Nota:
Ces tasseaux bruts permettent
de réaliser des tasseaux avec
toutes sortes de taraudage.

